

Cooling modifications

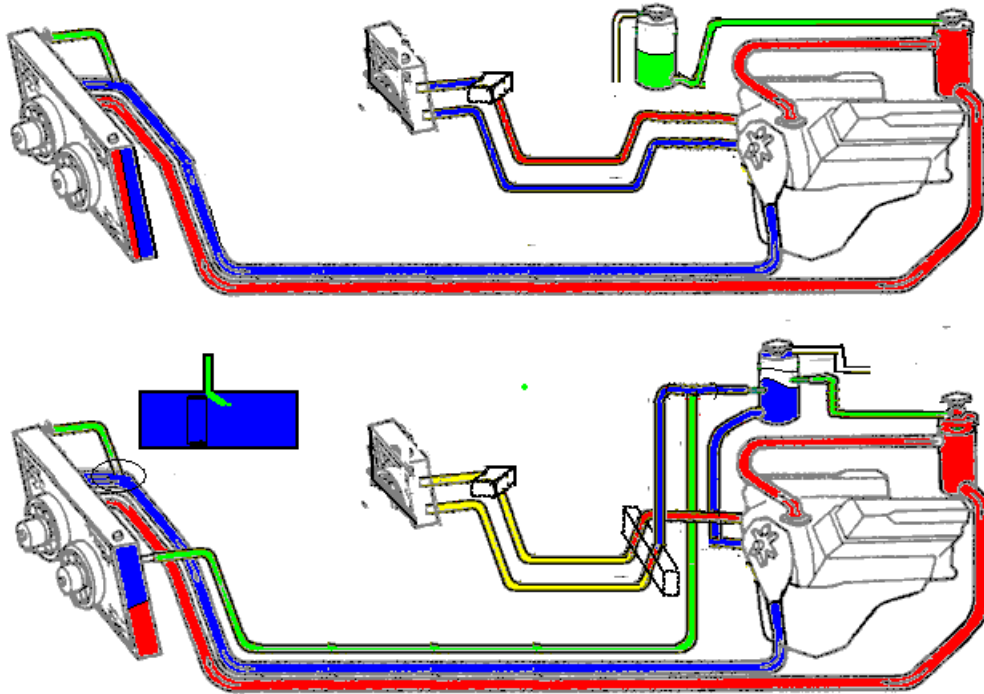

The original (upper)

The hot coolant from the thermostat goes to a swirl tank with the 13 psig pressure cap. The “heat swell” over flow went to a reservoir tank with a plain cap. Upon cool down, coolant should be pulled back into swirl.

The radiator is dual pass with original vertical baffle. Early mod changed baffle to horizontal and due to outlet being near center of the tank an upper vent tube was added per factory TSBs.

Desired (lower)

Convert the reservoir to a pressure tank. Place the plain cap on the swirl and 13psig pressure cap on pressure tank. Need to verify the neck dimensions allow cap to lift at rated. Upgrade vent hose for pressure and add 1/8” orifice so that the swirl is continuously vent to the pressure tank. will need to add/move for following barbed connections;

- 1) The original nipple for vent needs to be raised to 1/3 from bottom
- 2) 5/8 heater hose connection at 1/3 from bottom to receive the heater return (and radiator vent)
- 3) 5/8 heater hose connection at bottom for return to water pump suction
- 4) ~~(not shown) Near the top of the tank a port for scharder valve (to use air to verify cap relief pressure)~~

The pressure tank is connected to the pump suction at the water pump heater nipple. The pressure tank will need to be raised to allow about 7" of air space with its level at the top of the swirl. To access the pressure tank cap, a hole will need to be cut in the right hand engine cover

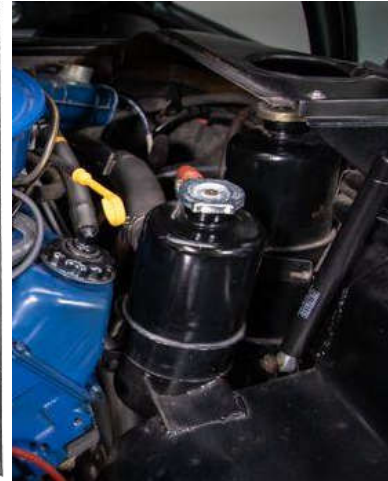
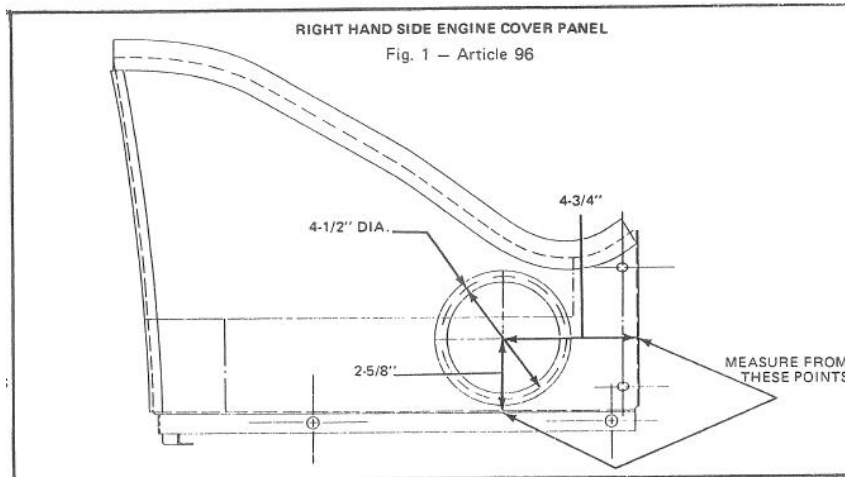

The plain cap on the swirl needs to be safety wired so not to accidentally open

Factory Mod (TSB A-19) added an upper radiator outlet tank vent (hose 37) down to the return tube (18). ~~To enhance the venting capability, I would like to install a thin sleeve in the return tube, just up stream of the vent hose connection to create a slight venture suction.~~

A second factory mod (TSB A-61) recommended was to vent the radiator's end tank back to the engine bay. This design was flawed as it connected to the swirl tank (higher pressure than radiator). I didn't have this mod, so the tube 37c was not under the car.

The shown desired has radiator left end tank's vent going to the pressure tank (water pump suction pressure). An $\sim 3/8$ SS tube will need to be fitted under the car with barbed ends for hose connections

The heater control valve is at the core in the cabin. I would like to add an electronic controlled shutoff in the engine bay. This valve should be part of the HVAC mod (hopefully a 4 way). The heater return then routed to the pressure tank.

SECTION 11 ILLUSTRATION 18

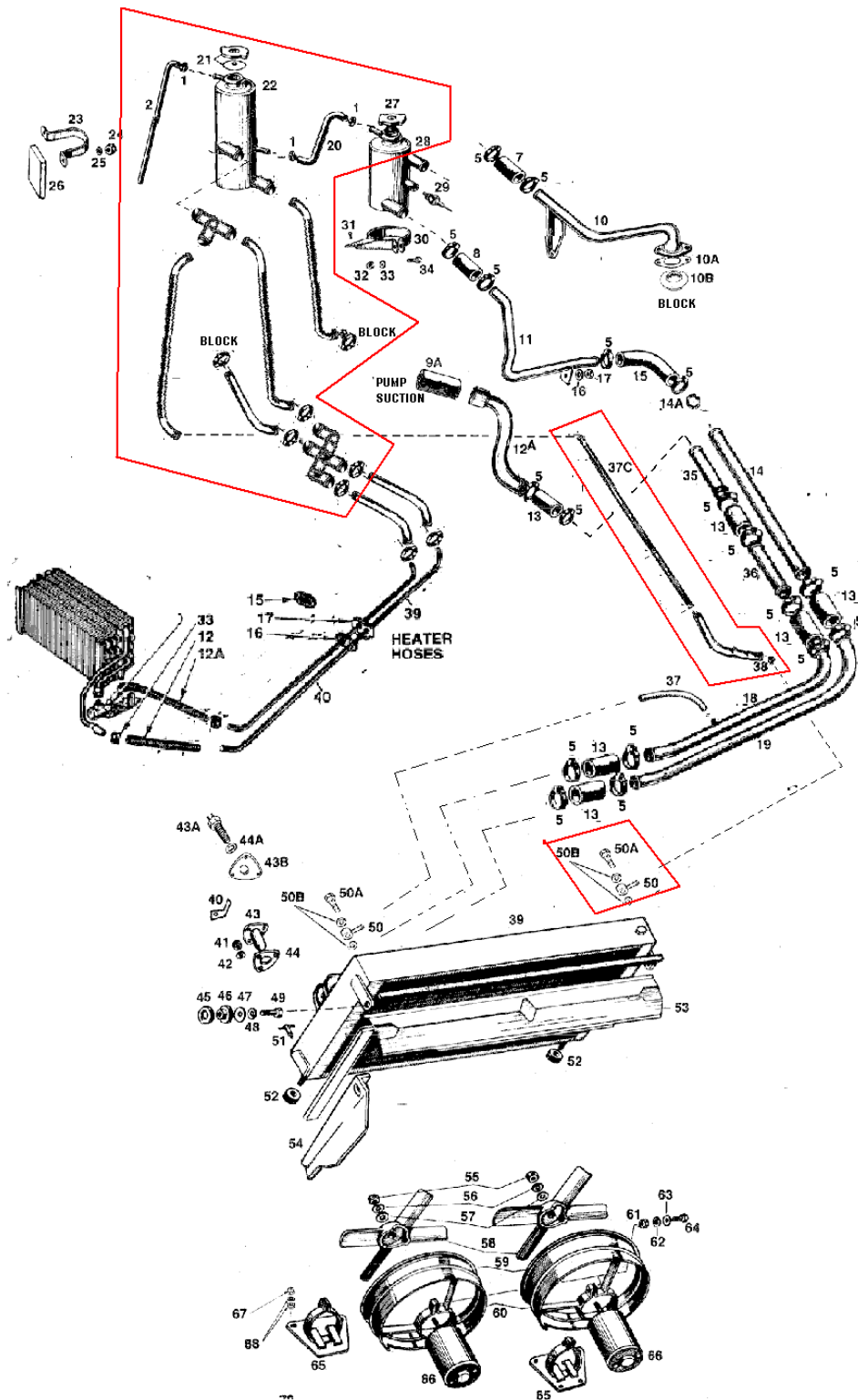

The original temperature sender was located in the swirl tank, thus not measuring hot coolant until the thermostat opens. The normal sender location is at the front of the block, just under the thermostat. However the gauge scaling has normal 190F near full scale. I want to install the sender in the water pump inlet. I expect it to read 160F at normal. Then add a 220F switch in the block location for idiot light.

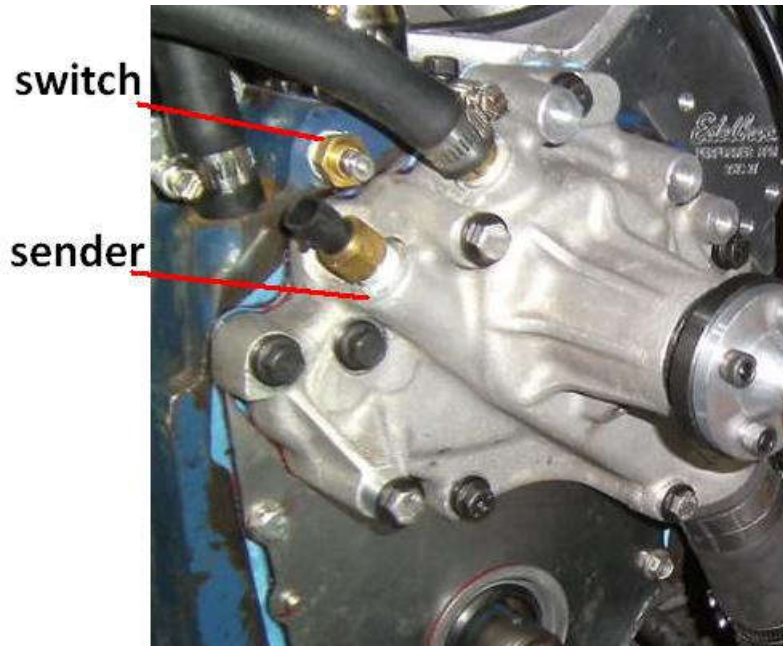

Some have found that the mod of the radiator tank for horizontal baffle did not separate the upper/lower section of the end tank, but allow flow leak by. Need to make sure horizontal baffle is effective.

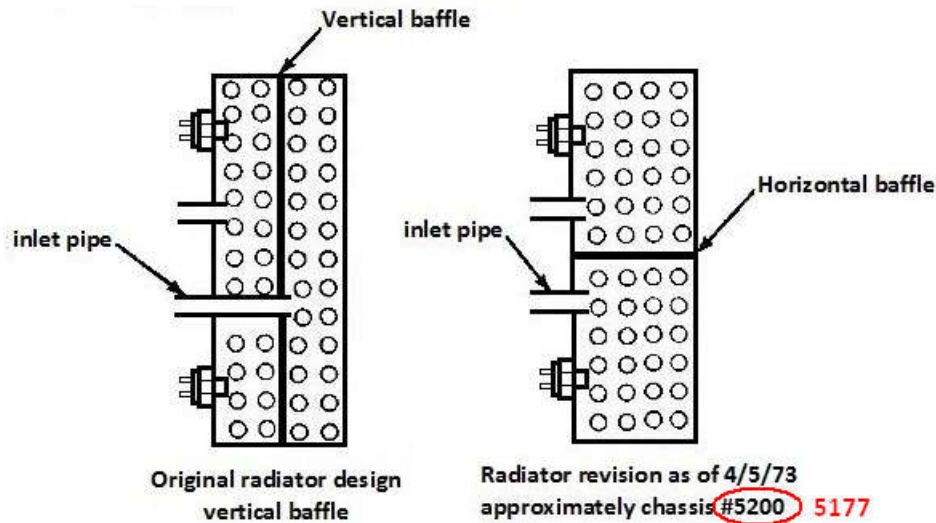

If the end tanks are removed (say for cleaning core), besides the right end tank's horizontal baffle, I would like to add vertical baffle to the left tank. this being a flow guide to reduce turbulence and thus not needing to have full seal with it only 90% from the bottom.

The original two radiator fans used two switches, one set at 160F and the second at 180F. they were both in the radiator discharge tank. However with the horizontal baffle mod, the lower switch now senses hot inlet. I want to use the switch in the upper discharge cooler section of the end tank wired to start both fans at 160F.

My harness should have the fan switches driving relays to power the fans. The original wire gauge may cause voltage drop at fans so adding a second power wire may be desired to get fan speeds up.

Water pump. drive pulley. Thermostat. fans
to be added